



COMPOST BINS

OBJECTIVE/GOAL:

To provide homeowners with guidelines for the installation of a compost bin in communities where they are allowed in Montgomery Village.

GUIDELINE DETAILS:

- Compost bins must be placed in rear yards in the least visible location.
- Only leaves and grass may be composted.
- Compost bins will be considered on an individual basis.
- No fee is required with the application only if one of the attached compost bin types are to be used
- Any other compost bin types will require a review fee with the application
- Acceptable compost bin types will depend on the type of community where the residence is located.
- Compost bins will not be permitted in high density communities with very small yards, back-to-back house communities, or communities with four-plex “corner” houses.
- All containers must be monitored by the homeowner with regards to safety and health issues.

APPLICATION CHECKLIST (items to include with your application):

- PIR (Property Improvement Request) form must be completed and signed by the property owner.
- A house location plat showing the location of the compost bin on the property.
- The measurement, materials and color of the compost bin.

Questions: Call Architectural Standards (301) 948-0110

All Architectural Standards information including community criteria is available on www.montgomeryvillage.com.

Approved January 2010, Revised 9/20/11, Revised 10/10/11

COMPOST CONTAINERS MONTGOMERY VILLAGE

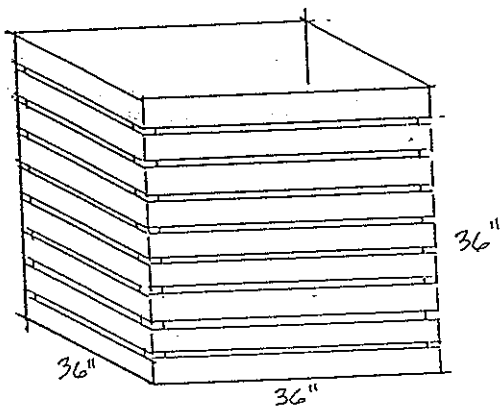

WOOD BOX Pressure treated lattice.

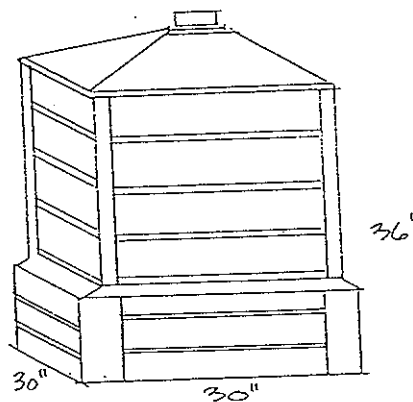

CHAMBERED BIN
Vinyl in earthtone colors.

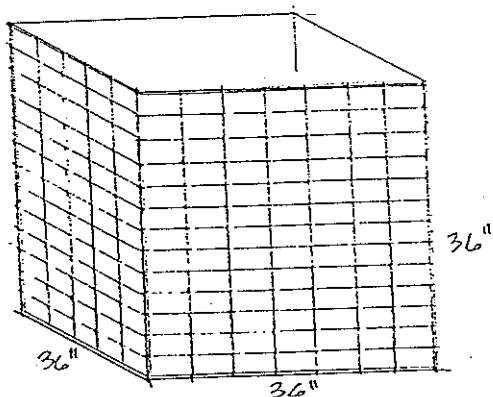

WIRE CAGE Galv. wire or green Vinyl coated.